

ELECTRIC OIL EXTRACTOR SET



1. FEATURES

2. SPECIFICATIONS

3. INSTRUCTIONS

1. FEATURES

- Cordless, battery powered oil suction tool set is easy to carry and move around - no need to connect to electrical cable or shop air.
- Includes 3 Panasonic® rechargeable batteries, and a 100 - 240V charging cable.
- It takes 2.5 hours to fully recharge the batteries.
- Tank capacity: 5.5 liter / 5.8 quart. Special materials that can be made transparent, heat resistant and suitable for extracting engine oil, coolant, and ATF.
- Extension tubes with outer diameters in Ø 4mm, 6mm, 8mm, suitable for oil dipstick tubes on different car makes.
- Total tube length 1,800 mm / 5.9 ft (main tube connected with an extension tube) can reach oil dipsticks on tall engine bays on pickup trucks.
- Extension tube storage system and tank lid can be detached easily for cleaning purposes.
- Sturdy round base that does not wobble.

2. SPECIFICATIONS

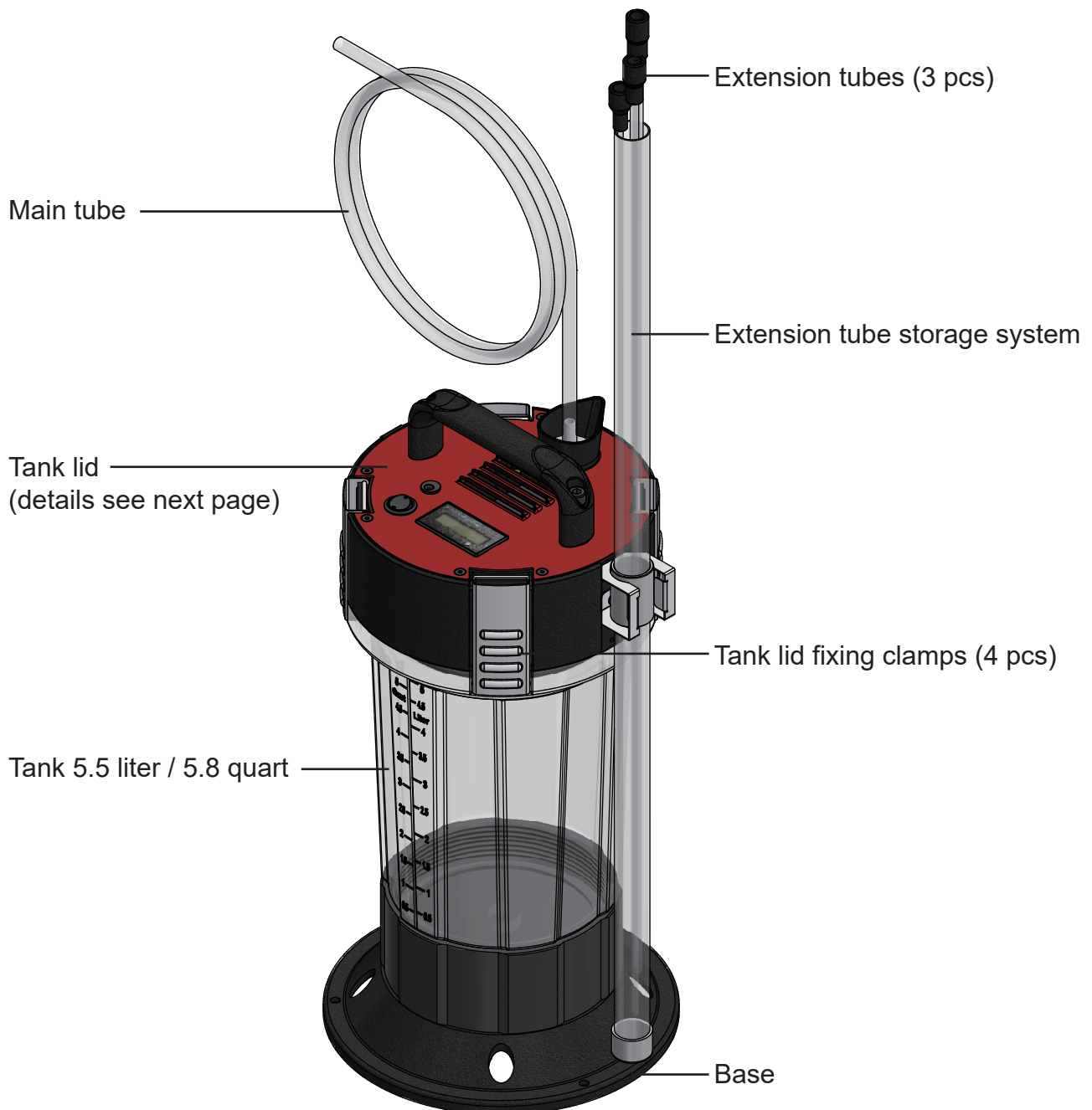

Automatic pressure release valve

Waste fluid pour spout

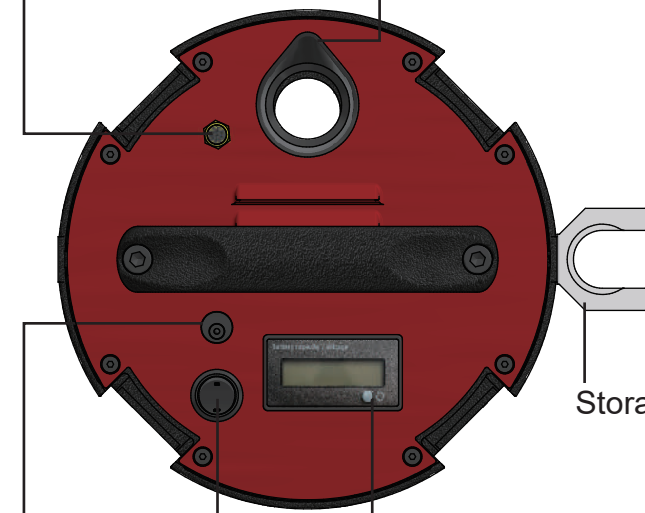

Storage holder

Charger port

Switch

Battery level display

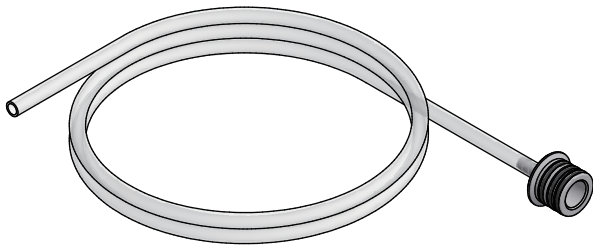

Inner diameter (ID) \varnothing 7.5 mm
Outer diameter (OD) \varnothing 10 mm

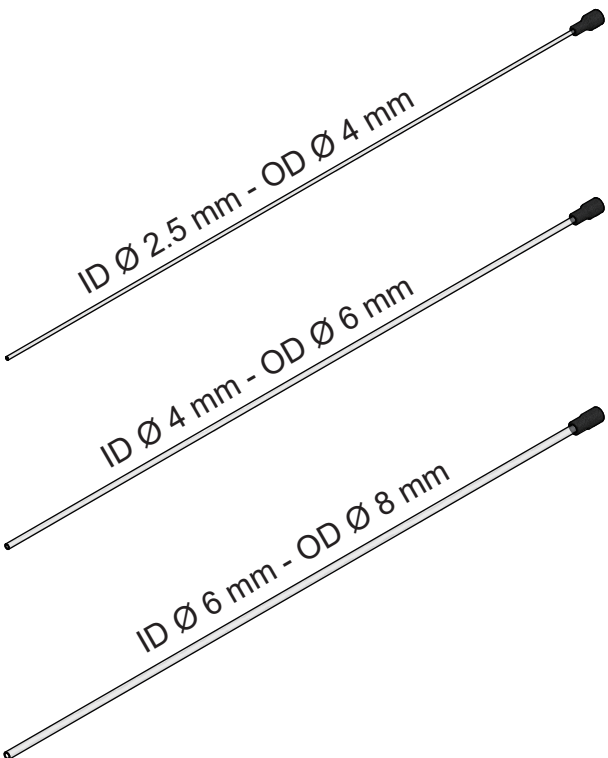
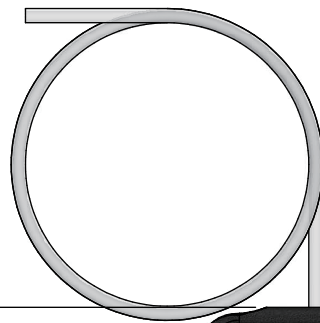

ID \varnothing 2.5 mm - OD \varnothing 4 mm

ID \varnothing 4 mm - OD \varnothing 6 mm

ID \varnothing 6 mm - OD \varnothing 8 mm

58 mm / 2.3"

445 mm / 17.5"

823 mm / 32.4"

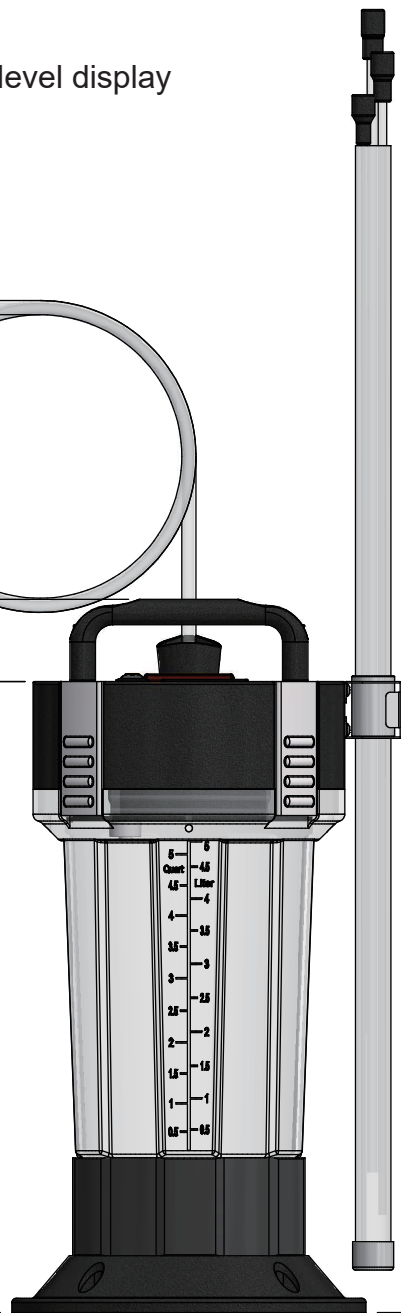

\varnothing 250 mm / \varnothing 9.8"

3. INSTRUCTIONS



CAUTION



- Always read the instructions carefully before using the tool
- Always perform air bleeding before introducing brake fluid into brake system
- Always perform a low pressure test to ensure no leaks before increasing pressure
- Ensure the working area has adequate lighting
- Keep children and unauthorized persons away from the working area
- Keep working area clean and tidy, dry and free from unrelated materials
- DO NOT allow untrained persons to use this tool kit
- Always wear eye protection that meets OSHA and ANSI Z87.1 standards
- Always wear gloves when working with the tool
- Always wear ear protection
- Disposal: Customers should follow local regulations to handle used/waste parts